

Sequencing of Von Hippel-Lindau (VHL) Gene from Genomic DNA for Mutation Detection in Italian Patients

Akanni OE* and Ferrari M[#]

* Department of Haematology & Blood Transfusion, College of Health Science, Ladoko Akintola

University of Technology, P.M.B 4400, OS 230001, Osogbo . Nigeria

olufemiakanni@yahoo.com

[#]Clinical Molecular Biology & Cytogenetic Laboratory, Diagnostica e Ricerca, San Raffaele Hospital, Milan, Italy

Abstract

Genomic DNA from patients suspected to have VHL were analysed by direct sequencing of the VHL gene-coding region for mutation detection. Sequencing was performed on the extracted DNA following amplification by Polymerase Chain Reaction (PCR) with suitably designed primers. Genetic analysis revealed a single base substitution in exon 3 of each of the two patients causing the R161X (stop codon) being a de novo mutation and the R176W missense mutation, respectively. The genetic and familial studies indicated that the VHL disease is inherited as a dominant trait.

Key words: von Hippel-Lindau disease, VHL gene, mutation, tumour suppressor, polymerase chain reaction.

Introduction

The von Hippel-Lindau disease is an autosomal dominant genetic disorder described with retinal angiomas and their association with central nervous system lesions (1). The disease is characterized by an increased risk of blood vessel tumours (hemangioblastomas) and renal cell carcinomas (2).

The disease, although once thought to be rare, is one of the most common familial cancers. It is caused by a mutation in a gene responsible for tumour suppression (3). The von Hippel-Lindau (VHL) gene identified through linkage analyses and molecular cloning has been pointed to be responsible for the disease (4,5). The VHL gene isolated in 1993 (1) is a tumour-suppressor gene which resides on chromosome 3p25 and it is mutated or silenced in >50% of sporadic clear cell renal cell carcinomas (2).

Structurally, VHL gene is a small gene composed of three exons (NCBI accession number

L 15409) (6).

Materials and Methods

The genetic analysis was performed by direct sequencing of PCR products obtained from genomic DNA extracted from the patients peripheral blood leukocytes using the DNA extractor BIO ROBOT EZ 1 (Qiagen). The 3 exons of the gene were amplified by PCR using the primers designed as follows:

EXON 1-5' 5'- C G A A G A C T A C G G A G G A G G T C G A - 3'

EXON 1-3 5' - G G T A G A G G G G C T T C A G A C - 3'

EXON 2-5' 5'- A G G T G T G G G C C A C C G T G - 3'

EXON 2-3' 5'- T T C A A G G T G G T C T A T C C T G A C - 3'

EXON 3-5' 5'- T T C C T T G T A C T G A G A C C C T A G T - 3'

EXON 3-3' 5' - C A T C A G T A C C A T C A A A G C T - 3'

The PCR reaction mix contained 2 µl of primer [30 pmol/µl]: 0-8 µl of dNTPs [25 mM]; 10 µl of Buffer[10x]; 3µl of MgCl₂ [25 mM], 0.6 µl of Taq polymerase [2.5 U/µl] and H₂O to a final volume of 100 µl. The reaction was subjected to an initial incubation at 96°C for 10 minutes, followed by the amplification programme with denaturation at 96°C, annealing at 60°C and extension step at 72°C for 1 minute each for 35 cycles. A final step at 72° C for 10 minutes was performed.

The PCR products were purified on a liquid handler Multiprobe II HTEX (Perkin Elmer) and the sequencing reaction were performed with the reaction mix containing dNTPs, labelled ddNTPs, Taq polymerase and buffer as supplied by the manufacturer in the sequencing kit DYEnamic ET Terminator (Amersham Biosciences). The sequencing reaction contained 4.0 µl mix, 1.0 µl primer [1.6 pm/ µl], with 5.0 µl of PCR purified product [30 ng].

The reaction was loaded on a 3100 Genetic analyser (Applied Biosystems) according to the manufacture's recommendations. Electropherograms obtained were compared with the normal VHL gene NCBI reference sequence.

Results

A single point mutation (substitution) was detected in the exon 3 of VHL gene in each of the two patients. In patient II/1 (Figure 1) the 8684 C->T substitution causing the nonsense R161X mutation in the putative protein was found. On the other hand, the 8702C->T substitution was detected in patient II/3 (Figure 2) resulting in the R167W codon change.

FIG. 1

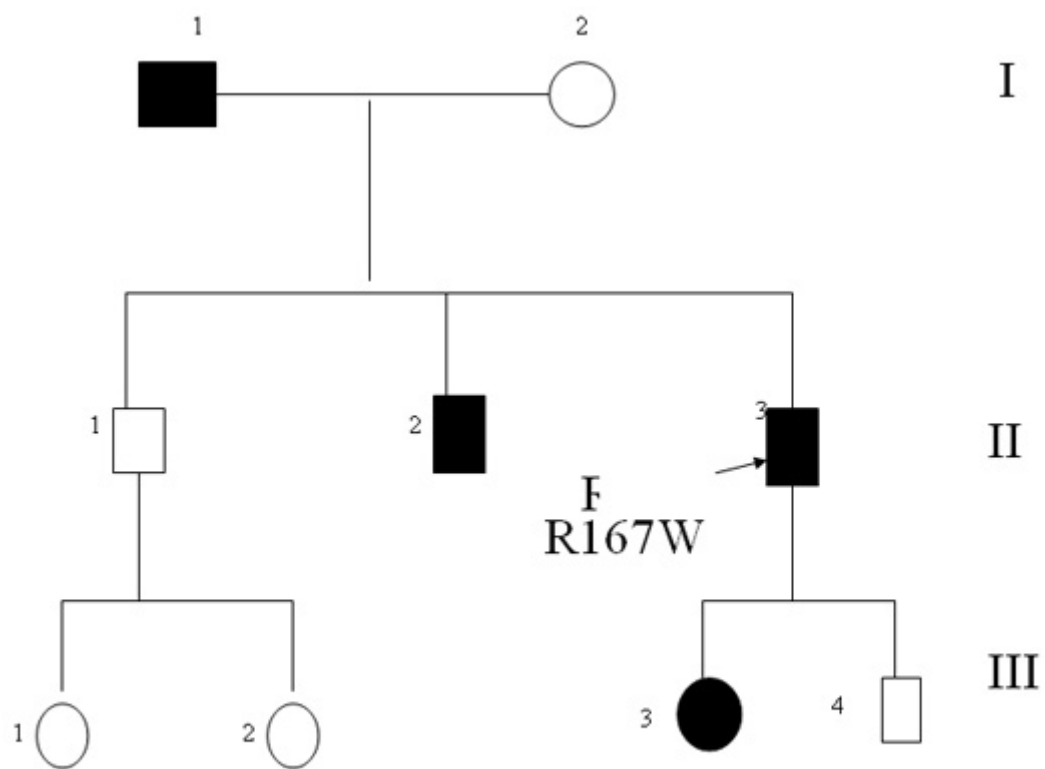
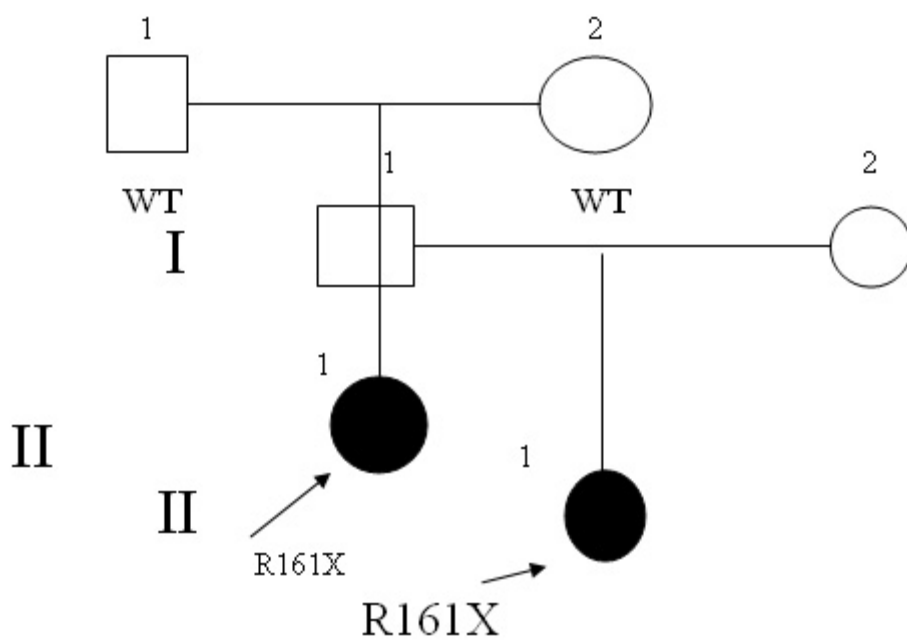

FIG. 2

Pedigrees of families with the R161X and R167W. Arrow indicates the proband.

Discussion

This study detected germline mutations in two unrelated Italian patients. Familial study on patients with the R161X mutation (Figure 1, II/1) revealed no VHL gene mutation in both parents (Figure 1, I/1, I/2). Thus patient, the only child of the family, is a sporadic case showing a de novo mutation in the VHL gene. She developed cerebellar hemangioblastoma at age 33. It was reported by (7) that germline de novo mutations may be present in as many as 23% of VHL patients since first generation diagnosis has been reported in 42 of 181 VHL kindreds evaluated.

In the second case, the proband II/3 with R167W mutation (Figure 2) inherited the VHL mutated gene from his father (Figure 2, I/1), who had haemangioblastoma. The patient developed retina angioma with renal carcinoma. His brother (Figure 2, II/2) also manifested renal carcinoma, central nervous system haemangioblastoma, pheochromocytoma and pancreatic cysts. One of his two children (III/3) also developed the disease. The R167W mutation was identified in all symptomatic subjects of this family (Figure 2, I/1, II/2, II/3, III/3).

Both mutations identified in this work have already been described in VHL patients, thus the clinical diagnosis was confirmed at the molecular level in the patients. It is therefore possible to offer genetic counselling to the patients and their relatives.

In this protocol, direct sequencing was employed for detection of mutations in the VHL gene. This protocol allows detection of small insertions, deletions or point mutations but not detection of large rearrangements for which Southern blot or multiple ligation probe amplification (MLPA) is required.

Since about 80% of patients with VHL gene have small rearrangements and about 20% have large deletions (8), a complete mutation detection in VHL patients would require the combination of two protocols each suited for detection of different rearrangements.

Acknowledgements

I would like to acknowledge the International Federation of Clinical Chemistry and Laboratory Medicine (IFCC) for its enormous support (PSEP fellowship), the entire staff of the host laboratories and the Medical Systems S.p.A. for their cooperations and contributions.

I am also grateful to the Nigerian Association for Clinical Chemists (NACC) and Ladoké Akintola University of Technology, Ogbomoso, Nigeria.

References:

Wiesener M, Eckardt K-U. Erythropoiesis, tumours and the von Hippel- Lindau gene: towards identification of mechanisms and dysfunction of oxygen sensing. *Nephrol Dial. Transplant.* 2002; 17: 356-9.
Kaelin W Jr, The von Hippel-Lindau Tumour Suppressor Gene and Kidney Cancer. *Clin*

Cancer Research. 2002 :10; S6290-5

Jeff Allred. Von Hippel-Lindau disease: Case studies in virtual Genetics 1996- 1997.

Kjeld P van Houwelingen, Boukje AC van Dijk, Christina A Hulsbergen- van de kaa, Leo J. Schouten, Hanneke JM Gorissen, Jack A Schalken. Prevalence of von Hippel- Lindau gene mutations in sporadic renal cell carcinoma: results from the Netherlands cohort study. BMC Cancer 2005, 5:57-67.

Latif F, Tory K, Gnarr J, et al. Identification of the von Hippel-Lindau disease Tumour suppressor Gene Science. 1993; 260: 1317-20.

National Centre for Biotechnology Information (NCBI) <http://www.ncbi.nih.gov>

Sgambati MT, Stolle C, Choyke PL, Walther MM, Zbar B, Linehan WM et al Mosaicism in VHL disease: lessons from kindreds with germline mutation identified in offspring with mosaic parents. Am J Hum Genet 2000;66: 84-91.

Maher ER, Webster AR, Richards FM, Green JS, Crossey PA, Payne SJ et al. Phenotypic expression in von Hippel-Lindau disease: correlations with germline VHL gene mutations. J Med Genet.1996; 4:328-32